



ComInTec®
Safety in Power Transmission

BACKLASH FREE TORQUE LIMITER

up to 1,200 Nm and 65 mm bore diameters



Ed.04/2024



- Download catalogue
- Download instruction sheets
- Download 3D and 2D cad model

DSS/SG

DSS/SG - backlash free torque limiter: introduction

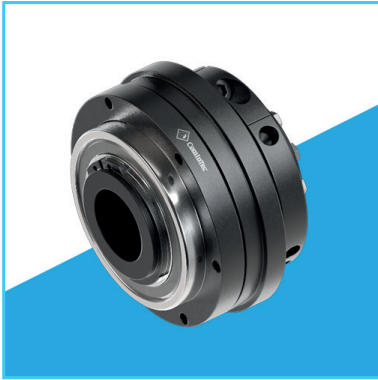

- ⦿ Exact torque regulation through a balanced radial nut.
 - ⦿ Innovative calibration system by "H dimension" for an immediate calibration of the device.
 - ⦿ Re-engagement in equidistant phase (DSS/SG) or 360° (DSS/F/SG).
 - ⦿ Maintenance free.
 - ⦿ Possibility to add a microswitch / proximity to stop the motor drive.
 - ⦿ Model available only with finished bore.
 - ⦿ Drive component assembled and directly supported by a ball bearing.
- ON REQUEST
- ⦿ Complete with transmission component worked and assembled (plate wheel, pulley, gear,...)
 - ⦿ Possibility of connection with 8 holes interchangeable with other products on the market.
 - ⦿ Possibility to have a connection flange to the most common intermittent drive units.
 - ⦿ Feasibility in personalized phase at 30°, 45°, 60°, 90°, ...





A ball safety coupling with high technology and precision. Provides backlash free transmission of motion with high sensitivity of reaction and an immediate release without peak load prior to release. The device can be adjusted by changing the pressure of the springs in the negative.

MAIN APPLICATIONS

- ⦿ Print machines and packaging machines.
- ⦿ CNC tool machines.
- ⦿ Index tables, filling machines, guiders.
- ⦿ Servomotors, slide guides.

ADVANTAGES AND BENEFITS

- ⦿ To protect the product against faulty positioning on the rotating table.
- ⦿ To protect the indexing against overloading along the transmission.
- ⦿ To protect the operating units of machine tools against impacts.
- ⦿ To protect slides or servomotors against impact or limit stops.

	.../N: immediate disengagement when exceeding the calibration torque; low residual torque after the disengagement.	from 0,8 to 1,200 Nm 50 mm max. bore	Pag. 32
	... + GAS/CCE: connection by elastic coupling to accept high misalignments.	from 0,8 to 900 Nm 62 mm max. bore	Pag. 34
	... + GAS/SG: connection by elastic coupling and single split clamp hub for a quick installation.	from 0,8 to 900 Nm 60 mm max. bore	Pag. 35
	... + GSF: connection by bellows coupling for application with reduced inertia.	from 0.8 to 150 Nm 45 mm max. bore	Pag. 36

ASSEMBLY EXAMPLES

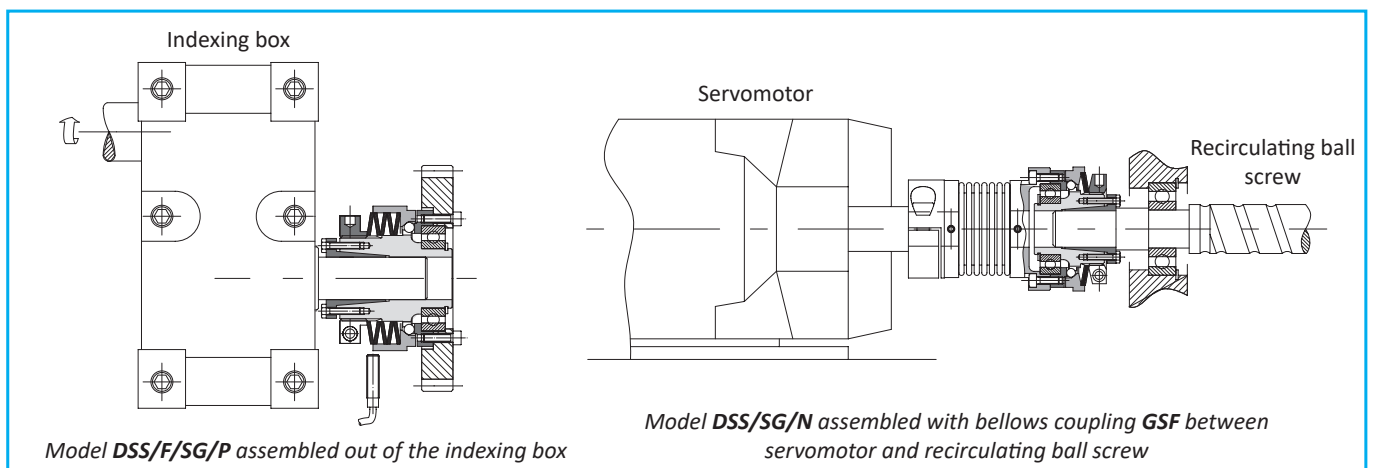

DSS/SG - backlash free torque limiter: versions

TORQUE ADJUSTMENT

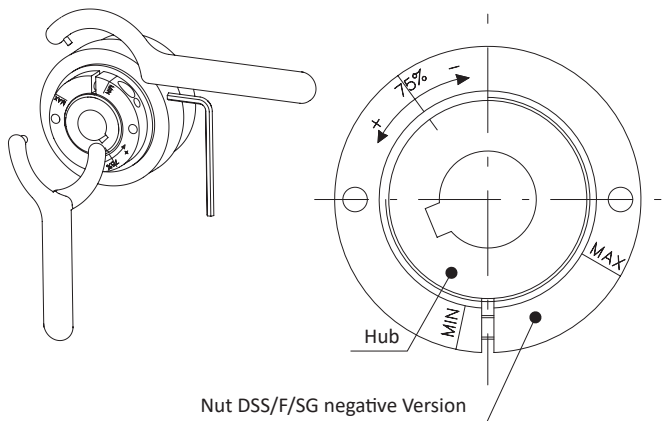
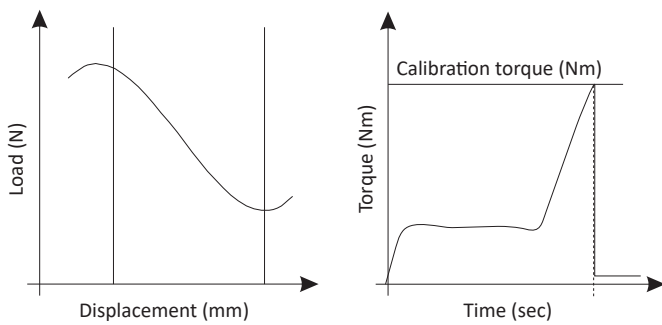

It generates an immediate torque reduction, as soon as there is a minor overload, with consequent disengagement of the limiter and immediate stop of the drive. This characteristic is very useful on sensitive applications where even a slight increase of the loads can cause damage to the machine or to the machine product.

Adjustment of the Negative version is opposite to all other units in our range. Unlike the traditional units, by rotating the adjuster nut clockwise the disengagement torque will reduce, and therefore to increase the torque the nut must be rotated anti-clockwise. To assist the operator in setting, there are clear markings on the nut showing 75% of the max torque and +/- Min/Max directions indicated.

Unless otherwise requested, these models are supplied pre-calibrated at 75% of the maximum torque value of the spring's chosen configuration.

OTHER MODELS



DSS/SG/N-SS: STAINLESS STEEL MODEL (consult the dedicated brochure)

- ⊙ Model without any backlash.
- ⊙ Same dimensions as the standard model, both in negative and positive versions.
- ⊙ Made in stainless steel at high resistance by suitable heat treatments.
- ⊙ High resistance to corrosion.
- ⊙ Suitable to food and/or pharmaceutical environments.
- ⊙ Torque range: 1,5 to 900 Nm; max. bore \varnothing 65 mm



MAINTENANCE

These devices, mechanical, are maintenance-free.

In the case of the torque is appropriate to take account of different variables that combined together can affect the length of the limiter:

- Torque intervention in relation to the range provided by the limiter.
- Whether the frequency and duration of interventions.
- Ability to dissipate heat generated by the sliding.
- Speed of rotation.
- Environmental working conditions.

.../N - NEGATIVE version with bore and keyway: technical data



- Angular backlash free with compact dimensions.
- Instantaneous torque transmission reduction when overloading.
- Free of residual torque after disengagement.
- Fastest response times and highest sensitivity.
- Available with extended hub to assemble wide drive components: .../ML.
- Torque range: 0.8 - 1,200 Nm; max. bore $\phi 65$ mm.

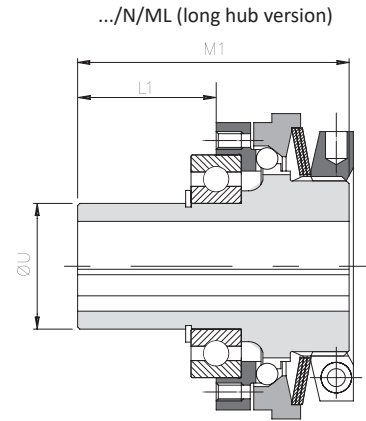
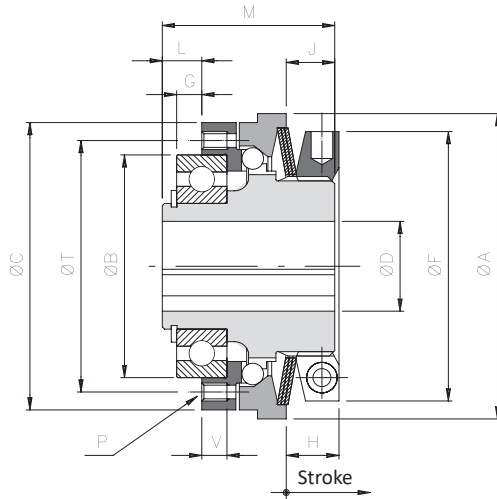

FOR TECHNICAL DATA
CONSULT THE
DEDICATED BROCHURE

DIMENSIONS

Size	A	B h5	C	DH7	F	* G	L	L1	J	P	M	M1	T	U h6	V	▲ On request "8C"						
				Max.												B h5	C	G	L	P	T	V
00.40	44	30	40	12	38	2	4,5	-	7	6xM3	24	-	35	-	5	-	-	-	-	-	-	-
00.47	50	37	47	17	42	2	5	-	8,5	6xM3	29	-	42	-	5	-	-	-	-	-	-	-
0.63	70	42	65	20	62	4	7	32	12	6xM5	40	65	48	30	7	47	-	5	8	8xM4	56	6
1.80	85	62	80	25	75	7	11	43	13,5	6xM5	48	80	70	35	7	-	-	-	-	8xM5	71	-
2.96	100	75	96	35	82	9	14	55	16	6xM6	59	100	89	45	9	-	95	-	-	8xM6	85	-
3.116	115	90	115	42	97	8	14	65	17	6xM8	64	115	105	55	12	-	110	10	16	8xM6	100	10
4.138	135	100	138	50	117	6,5	14,5	69,5	20,5	6xM10	75	130	125	65	14	-	130	10	18	8xM8	116	11
▲ 5.172	166	130	172	65	145	11	20	-	33	6xM12	105	160	155	85	18	-	166	12	21	8xM10	150	15

TECHNICAL DETAILS

Size	Torque [Nm]				Stroke [mm]	Inertia [Kgm ²]		Max speed [Rpm]	Weight [Kg]	
	T1	T2	T3	T4		Flange side	Nut side		.../N	.../N/ML
00.40	0,8 - 1,9	1,9 - 3,7	-	3,7 - 7,4	0,7	0,00009	0,00002	4000	0,2	-
00.47	2 - 5,8	5,3 - 12	-	11 - 24	1	0,000015	0,00004	4000	0,4	-
0.63	5 - 14	12 - 28	24 - 50	-	1,1	0,00008	0,00027	4000	0,9	1,0
1.80	9 - 28	18 - 60	40 - 100	-	1,3	0,00029	0,00068	3000	1,5	1,6
2.96	20 - 45	42 - 95	-	85 - 200	1,5	0,00068	0,00151	2500	2,8	3,0
3.116	35 - 100	75 - 200	-	195 - 415	2	0,00129	0,00262	2000	3,7	4,1
4.138	75 - 190	140 - 345	-	245 - 720	2,5	0,00315	0,00633	1200	6,7	7,3
▲ 5.172	160 - 335	280 - 650	-	500 - 1200	2,5	0,01012	0,02075	800	9,4	10,4

NOTES

▲ On request

- DH7*: maximum diameter for finished bore with reduced keyway according to UNI 7510.
- G*: assembly tolerance +0,1.
- Weights are relevant to the pilot bore; inertias refer to the maximum diameter for finished bore of the torque limiter (.../N).
- Microswitches EM1 and inductive sensor PRX see page 69

.../N - NEGATIVE version with hole and locking assembly: technical data

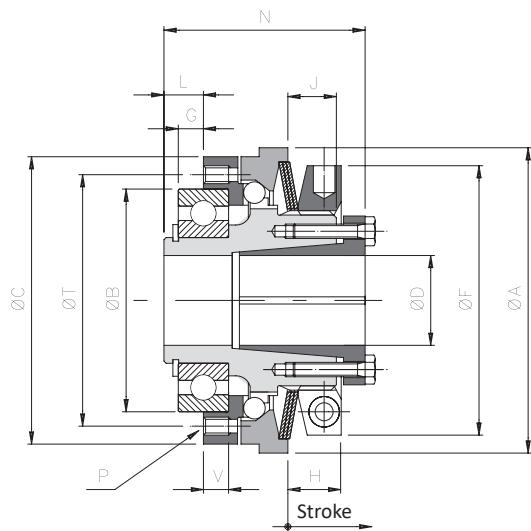

.../N/ML (long hub version)

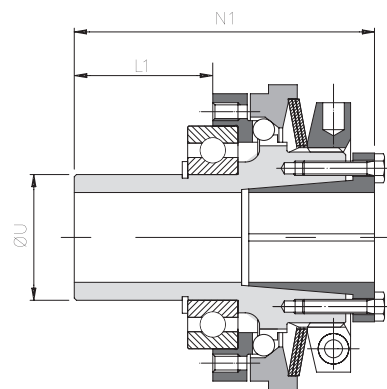

■ FOR TECHNICAL DATA
CONSULT THE
DEDICATED BROCHURE

DIMENSIONS

Size	A	B h5	C	D H7 Max.	F	* G	L	L1	J	P	N	N1	T	U h6	V	▲ On request "8C"								
																B h5	C	G	L	P	T	V		
00.40	44	30	40	12	38	2	4,5	-	7	6xM3	28,5	-	35	-	5	-	-	-	-	-	-	-	-	-
00.47	50	37	47	17	42	2	5	-	8,5	6xM3	34,5	-	42	-	5	-	-	-	-	-	-	-	-	-
0.63	70	42	65	20	62	4	7	32	12	6xM5	47	72	48	30	7	47	-	5	8	8xM4	56	6	-	-
1.80	85	62	80	25	75	7	11	43	13,5	6xM5	56	88	70	35	7	-	-	-	-	8xM5	71	-	-	-
2.96	100	75	96	35	82	9	14	55	16	6xM6	67	108	89	45	9	-	95	-	-	8xM6	85	-	-	-
3.116	115	90	115	42	97	8	14	65	17	6xM8	73	124	105	55	12	-	110	10	16	8xM6	100	10	-	-
4.138	135	100	138	50	117	6,5	14,5	69,5	20,5	6xM10	86	141	125	65	14	-	130	10	18	8xM8	116	11	-	-
▲ 5.172	166	130	172	65	145	11	20	-	33	6xM12	120	175	155	85	18	-	166	12	21	8xM10	150	15	-	-

TECHNICAL DETAILS

Size	Torque [Nm]				Stroke [mm]	Locking assembly		Inertia [kgm ²]		Max speed [Rpm]	Weight [kg]	
	T1	T2	T3	T4		Screws	Tightening torque [Nm]	Flange side	Nut side		.../N	.../N/ML
00.40	0,8 - 1,9	1,9 - 3,7	-	3,7 - 7,4	0,7	6xM3	1,5	0,000009	0,00002	4000	0,2	-
00.47	2 - 5,8	5,3 - 12	-	11 - 24	1	6xM3	1,5	0,000015	0,00004	4000	0,4	-
0.63	5 - 14	12 - 28	24 - 50	-	1,1	6xM4	4,1	0,00008	0,00028	4000	0,9	1,0
1.80	9 - 28	18 - 60	40 - 100	-	1,3	8xM4	4,1	0,00029	0,00071	3000	1,6	1,7
2.96	20 - 45	42 - 95	-	85 - 200	1,5	10xM4	4,1	0,00068	0,00158	2500	3,0	3,2
3.116	35 - 100	75 - 200	-	195 - 415	2	8xM5	8,5	0,00129	0,00282	2000	4,1	4,7
4.138	75 - 190	140 - 345	-	245 - 720	2,5	8xM6	14	0,00315	0,00682	1200	7,3	7,9
▲ 5.172	160 - 335	280 - 650	-	500 - 1200	2,5	8xM8	35	0,01012	0,02154	800	9,8	10,8

NOTES

▲ On request

- G*: assembly tolerance +0,1.
- Weights are relevant to the pilot bore; inertias refer to the maximum diameter for finished bore of the torque limiter (.../N).
- Microswitches EM1 and inductive sensor PRX see page 69

... + GAS/SG/CCE - model with jaw coupling and external locking assembly: technical data

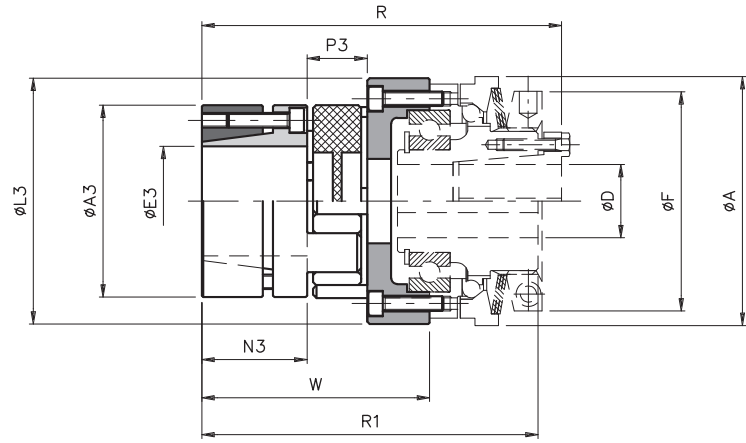

DIMENSIONS

Size		Torque [Nm]		A3	E3 H7 max	L3	N3	P3	A	D H7 max	F	W	R	R1
DSS/SG	GAS SG/CCE	Nom	Max											
00.40	01	12,5	25	30	16	12	11,5	12	44	12	38	33,5	57,5	53
00.47	00	17	34	40	20	49	25	16	50	17	42	53	82,5	77
0.63	0	60	120	55	28	65	30	18	70	20	62	63	102	95
1.80	1	160	320	65	38	84	35	20	85	25	75	74,5	119,5	111,5
2.96	2	325	650	80	48	102	45	24	100	35	82	93	146	138
3.116	3	450	900	95	55	122	50	26	115	42	97	100	159	150
4.138	4	525	1050	105	62	143	56	28	135	50	117	112,5	184	173
5.172	6	900	1800	135	75	178	75	35	165	65*	145	147	246	231

TECHNICAL DETAILS

Size		Clamp CCE		Misalignments			Rigidity			Inertia coupling side [Kgm ²]	Max speed [Rpm]	Weight [Kg]
DSS/SG	GAS SG/CCE	Screws	Tightening torque [Nm]	Angular α [°]	Axial X [mm]	Radial K [mm]	Torsional static [Nm/rad]	Torsional dynamic [Nm/rad]	Radial [N/mm]			
00.40	01	4xM2,5	0,75	0° 54'	+1/-0,5	0,09	170	510	605	0,00001	4000	0,15
00.47	00	6xM4	3		+1,2/-0,5	0,06	980	2340	2000	0,00013	4000	0,4
0.63	0	4xM5	6		+1,4/-0,5	0,10	3650	8100	2900	0,00040	4000	0,7
1.80	1	8xM5	6		+1,5/-0,7	0,11	4180	10700	3650	0,00107	3000	1,7
2.96	2	8xM6	10		+1,8/-0,7	0,12	8150	21850	5000	0,00296	2500	1,9
3.116	3	4xM8	35		+2,0/-1	0,15	15000	34000	5900	0,00559	2000	3,2
4.138	4	4xM8	35		+2,1/-1	0,16	16000	49000	6800	0,01213	1200	5,8
5.172	6	4xM12	120		+2,6/-1	0,18	38000	97000	6400	0,04301	800	11

TRANSMITTABLE TORQUE WITH LOCKING ASSEMBLY

Size GAS/SG/CCE	Transmission torque [Nm] according to the ø finished bore [mm]																											
	6	10	11	14	15	16	17	18	19	20	22	24	25	28	30	32	35	38	40	42	45	48	50	55	60	65	70	75
01 (14)	7	12	13	17	18	20																						
00 (19)		48	53	67	72	77	81	86	91	96																		
0 (24)					77	82	88	93	98	103	113	124	129	144														
1 (28)							186	196	206	227	247	258	289	309	330	361	392											
2 (38)										291	320	349	364	408	437	466	510	553	582	612	655	699						
3 (42)												485	545	584	623	681	740	779	818	876	934	973	1071					
4 (48)														584	623	681	740	779	818	876	934	973	1071	1168				
6 (55)																		1852	1944	2083	2222	2315	2546	2778	3009	3241	3472	

NOTES

▲ On request

- These details refer only for the coupling (GAS/CCE with backlash free red element 98 Shore-A), for torque limiters details see on page 32-33.
- Weights are relevant only to the pilot bore (GAS/CCE); inertias refer only the coupling with maximum bore (GAS/CCE).
- Microswitches EM1 and inductive sensor PRX see page 69

... + GAS/SG - model with jaw coupling and single split clamp hub type "B": technical data

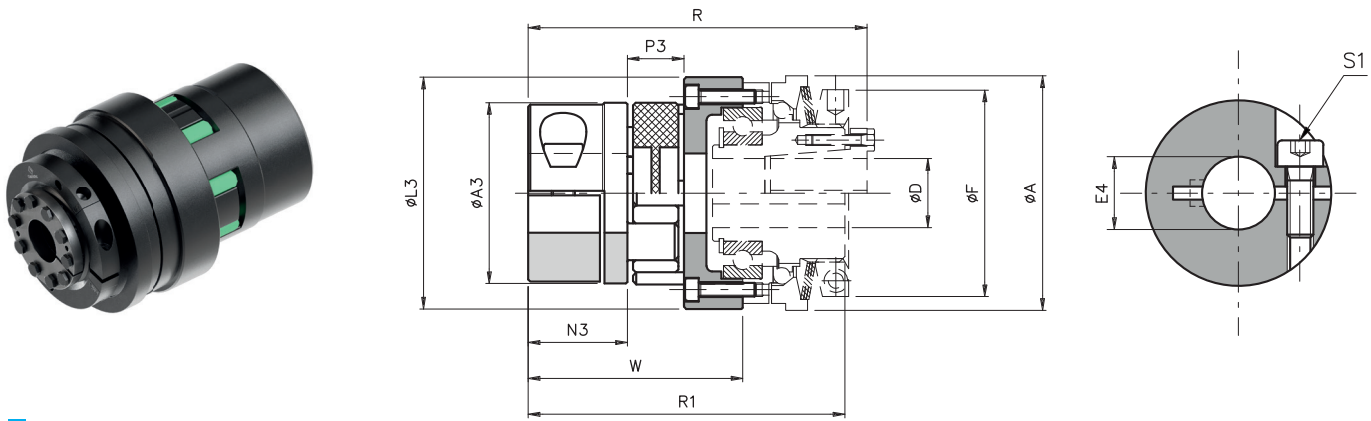

DIMENSIONS

Size		Torque [Nm]		A3	E4 H7 max	L3	N3	P3	A	D H7 max	F	W	R	R1
DSS/SG	GAS/SG	Nom	Max											
00.40	01	12,5	25	30	16	42	11,5	12	44	12	38	33,5	57,5	53
00.47	00	17	34	40	20	49	25	16	50	17	42	53	82,5	77
0.63	0	60	120	55	30	65	30	18	70	20	62	63	102	95
1.80	1	160	320	65	35	84	35	20	85	25	75	74,5	119,5	111,5
2.96	2	325	650	80	45	102	45	24	100	35	82	93	146	138
3.116	3	450	900	95	50	122	50	26	115	42	97	100	159	150
4.138	4	525	1050	105	60	143	56	28	135	50	117	112,5	184	173
5.172	6	900	1800	135	70	178	75	35	165	65*	145	147	246	231

TECHNICAL DETAILS

Size		Clamp hub		Misalignments			Rigidity			Inertia coupling side [Kgm ²]	Max speed [Rpm]	Weight [Kg]
DSS/SG	GAS/SG	Screw	Tightening torque [Nm]	Angular α [°]	Axial X [mm]	Radial K [mm]	Torsional static [Nm/rad]	Torsional dynamic [Nm/rad]	Radial [N/mm]			
00,40	01	M4	5	0° 54'	+1/-0,5	0,09	170	510	605	0,00001	4000	0,15
00.47	00	M5	8,7		+1,2/-0,5	0,06	980	2340	2000	0,00013	4000	0,4
0.63	0	M6	15		1,4/-0,5	0,10	3650	8100	2900	0,00040	4000	0,7
1.80	1	M8	36		1,5/-0,7	0,11	4180	10700	3650	0,00107	3000	1,7
2.96	2	M8	36		1,8/-0,7	0,12	8150	21850	5000	0,00296	2500	1,9
3.116	3	M10	70		2,0/-1	0,15	15000	34000	5900	0,00559	2000	3,2
4.138	4	M12	121		2,1/-1	0,16	16000	49000	6800	0,01213	1200	5,8
5.172	6	M12	121		2,6/-1	0,18	38000	97000	6400	0,04301	800	11

TRANSMITTABLE TORQUE WITH CLAMP HUB ASSEMBLY

Size GAS/SG	Transmission torque [Nm] according to the ø finished bore [mm]																													
	6	8	10	11	12	14	15	16	18	19	20	22	24	25	28	30	32	35	38	40	42	45	48	50	55	60	65	70	75	
01 (14)	21	23	24	25	26	27	28	▲29																						
00 (19)		45	47	49	50	52	53	55	57	58	60																			
0 (24)			77	78	80	83	84	86	88	90	91	94	97	98	103	106														
1 (28)					158	161	164	169	171	174	179	184	187	194	199	204	212													
2 (38)									193	196	198	203	208	211	218	223	228	236	243	248	253	260								
3 (42)											342	350	357	361	372	379	387	398	409	417	424	435	446	454						
4 (48)														569	585	596	607	623	639	650	661	677	693	704	731	758				
6 (65)																	753	769	780	791	807	823	834	861	888	915	942	970		

NOTES

▲ On request

- D H7*: finished bore max = 55 H7 for positive version with shrink disk.
- These details refer only for the coupling (GAS/SG with backlash free red element 98 Shore-A), for torque limiters details see on page 32-33.
- Weights are relevant only to the pilot bore (GAS/SG); inertias refer only the coupling with maximum bore (GAS/SG).
- Microswitches EM1 and inductive sensor PRX see page 69

... + GSF - model with bellows coupling: technical data

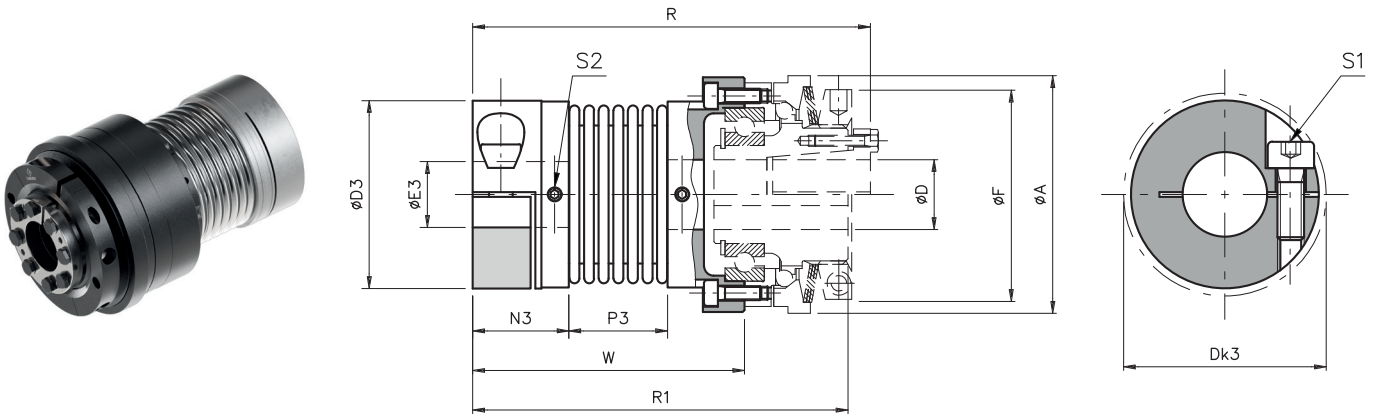

DIMENSIONS

Size		D3	Dk3	E3 F7		N3	P3	A	F	D H7	R	R1	W
SG	GSF			min.	max.								
00.40	1	34	36	5	16	17	16,5	44	38	12	72	67,5	48
00.47	2	40	44	8	20	20,5	21	50	42	17	87,5	82	58
0.63	3	55	58	10	30	22,5	27	70	62	20	107,5	100,5	68,5
1.80	4	65	73	14	38	26	32	85	75	25	126	118	81
2.96	5	83	89	14	45	31	41	100	82	35	155	147	102

TECHNICAL DETAILS

Size		Torque [Nm]		Screws S1	Grubscrews S2	Tightening torque		Misalignments			Rigidità			Inertia [Kgm ²]	Max speed [Rpm]	Weight [Kg]
SG	GSF	Nom	Max			Screws (S2)	Grubscr. (S2)	Angular α [°]	Axial X [mm]	Radial K [mm]	Torsional R _t [Nm/rad • 10 ³]	Axial R _a [N/mm]	Radial R _r [N/mm]			
00.40	1	5	10	M4	M3	2,9	0,8	1° 30'	±0,5	0,20	3,050	30	92	0,000024	4000	0,07
00.47	2	15	30	M5	M3	6	0,8	1° 30'	±0,6	0,20	7,000	45	129	0,000050	4000	0,14
0.63	3	35	70	M6	M4	10	2	2°	±0,8	0,25	16,300	69	160	0,000229	4000	0,29
1.80	4	65	130	M8	M4	25	2	2°	±0,8	0,25	33,000	74	227	0,000622	3000	0,45
2.96	5	150	300	M10	M4	49	2	2°	±1,0	0,30	64,100	87	480	0,000834	2500	0,93

TRANSMITTABLE TORQUE WITH LOCKING ASSEMBLY TYPE B

Size GSF	Transmission torque [Nm] according to the Ø finished bore [mm]																							
	5	6	7	8	9	10	11	12	14	15	16	18	19	20	24	25	28	30	32	35	38	40	42	45
1	5	6	7	8	9	10	11	12	14	15	16													
2				13	14	15	18	19	22	24	25	29	30	32										
3							25	27	32	34	36	41	43	45	54	57	63	68						
4												75	79	83	100	104	116	124	133	145	158			
5														132	158	165	183	198	211	231	248	263	277	295

NOTES

- These details refer only for the coupling (GSF), for torque limiters details see on page 34-37.
- Weights are relevant only to the pilot bore (GSF); inertias refer only the coupling with maximum bore (GSF).
- Microswitches EM1 or EM2 and inductive sensor PRX see page 73

DSS/SG - backlash free torque limiter: additional information

OTHER COUPLING ON REQUEST

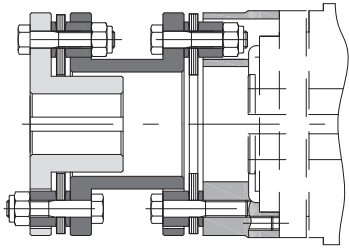

Model **DSS/SG** with double flexing torsionally rigid metal disc coupling **GTR/D** when torsional rigidity is required and ability to accommodate radial misalignment.

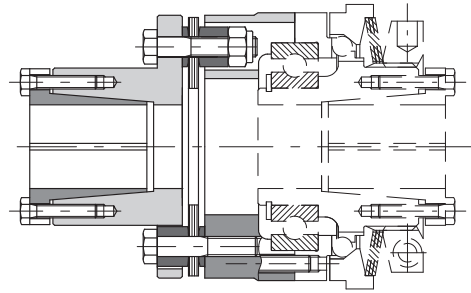

Model **DSS/SG** with single flexing disc coupling **GTR/S** for applications where torsional rigidity is required.

ORDER EXAMPLE

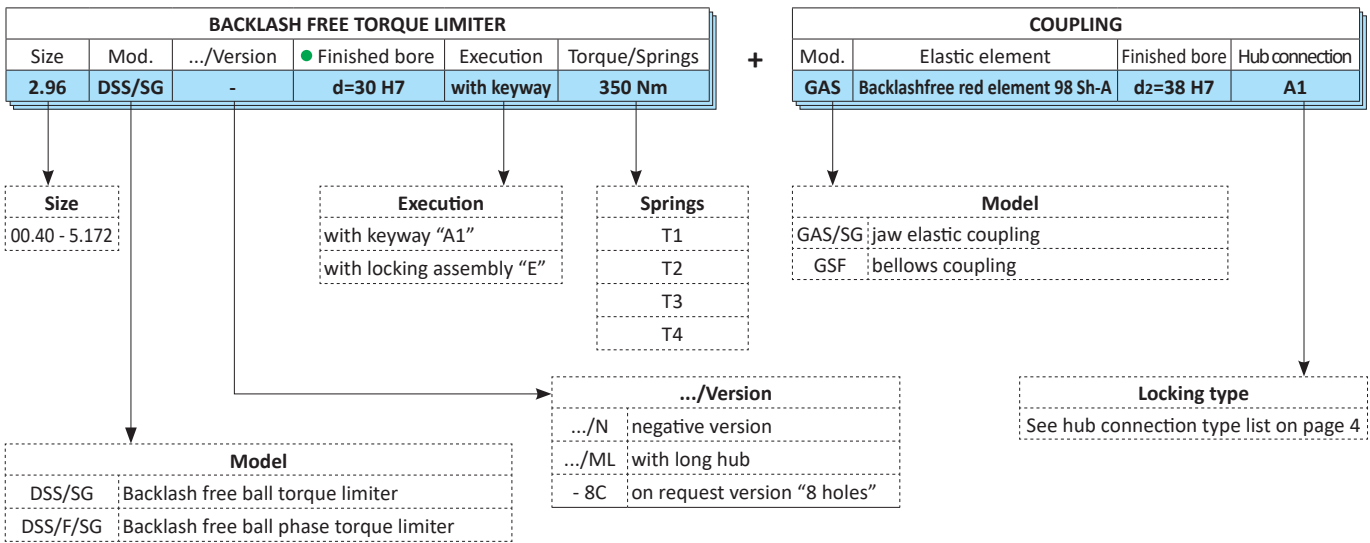

- Model available only with finished bore.